

design
make
play

SutcliffePlay

Waggon Lane
Upton Pontefract
West Yorkshire WF9 1JS
Telephone +44 (0) 1977 653200
Facsimile +44 (0) 1977 653222
info@sutcliffeplay.co.uk
www.sutcliffeplay.co.uk



Altitude - Crag

Installation Instructions

Mnw002

WARNING

Installation Instructions
Impact drivers

design
make
play
SutcliffePlay

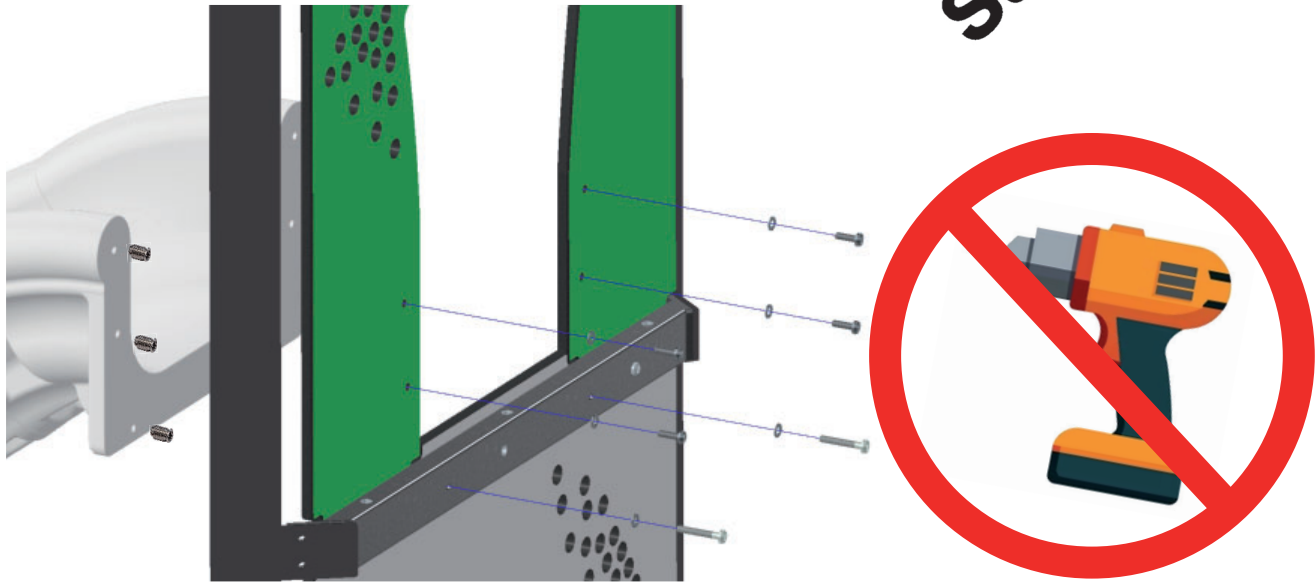

DO NOT use an impact driver when fixing bolts to self tapping inserts/threaded inserts.

The vibration of the impact driver can cause the insert to lose its grip on the post/slide and become ineffective.

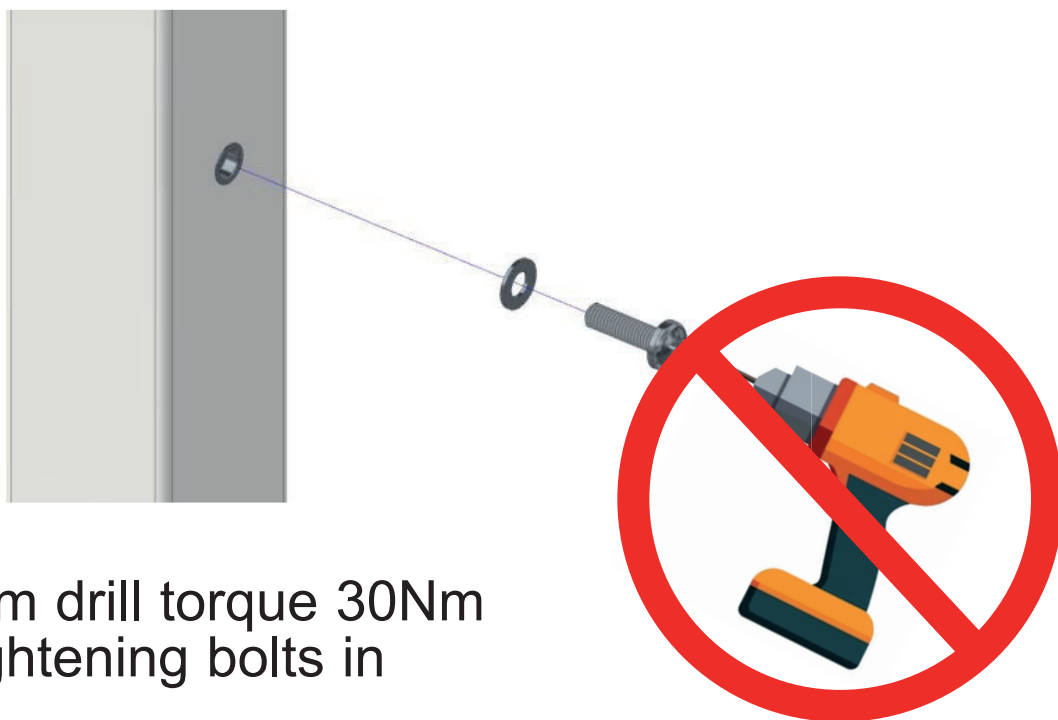

Maximum drill torque 30Nm
when tightening bolts in
fixings.

Mnw002

Unit Installation Instructions

1. Check using the Parts List that none of the components are missing.
2. Plan the final position of the play equipment ensuring there is sufficient space.
3. Sort and identify parts before assembly.
4. Excavate the foundation holes in accordance with the plan. Ensuring post holes are levelled and chocked in at the bottom of the holes.
5. Position 2 x 300mm long spragging irons into the holes provided in each post upright and stand in the foundation holes.
Do not tighten the fixing bolts until all the activities have been assembled.
6. Assemble the activities onto the posts as per the diagrams in this document. Leave fixing bolts loose until all the activities have been assembled. Ground fixed activities need 200mm spragging irons positioned through their holes.
7. Assemble the slide as per the diagrams in this document.
8. When all activities have been assembled, tighten all the fixings, attach nut covers where necessary, ensure the unit is level and the posts are vertical.
9. Fill the foundation holes to the required depth with concrete.
10. Do not allow the equipment to be used until the concrete has set (2 - 3 days) and the required safety surfacing has been installed.
11. Tighten all fixing bolts.
12. Follow the maintenance instructions supplied.

NB:

1. Slide runouts should be inclined downwards by approximately 2 degrees for drainage purposes.
2. During installation care must be taken to prevent hazards to children.
3. Extra care should be taken if conditions are abnormal.

Mnw002

Unit Parts List

Mnp002 x1
Set of 4
Posts



Mnd004 x1



Mnw002F x1



Mna028 x2

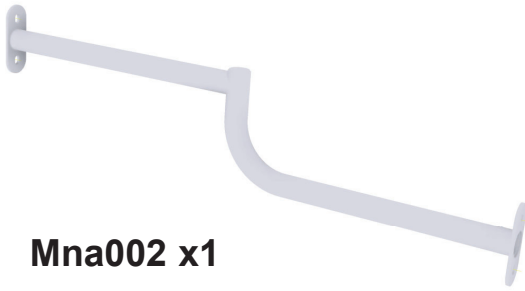

Mna002 x1

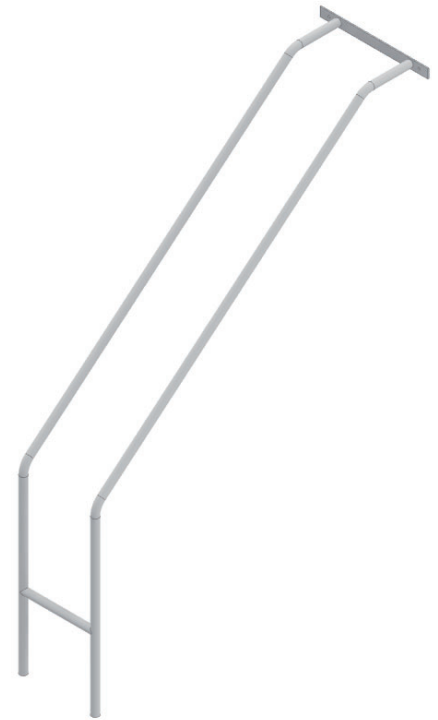

Mna030 x1

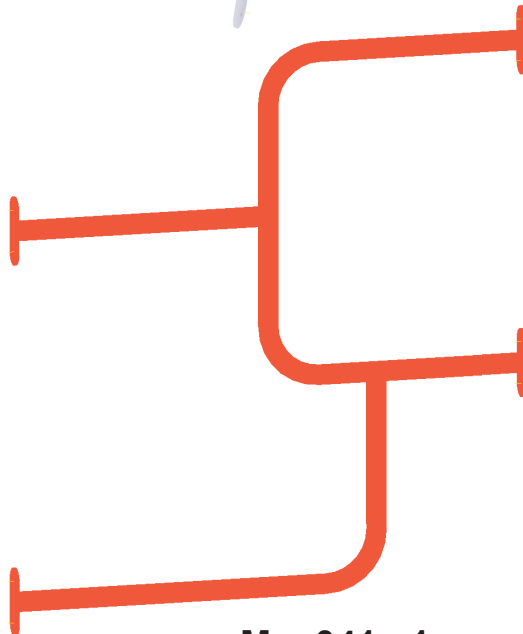

Mna041 x1

Mnw002

Unit
Parts List

design
make
play
SutcliffePlay

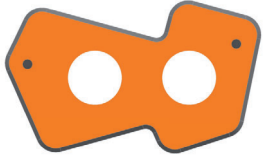

Mna027 x1

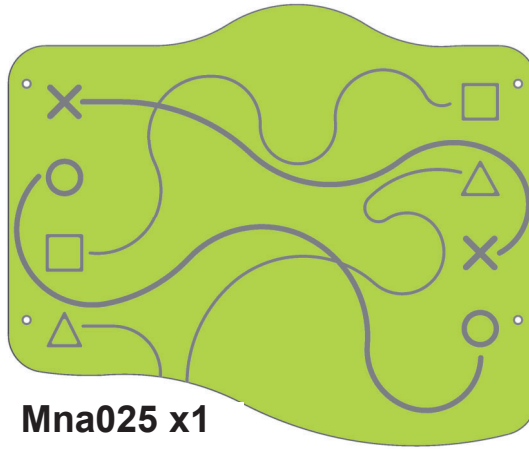

Mna025 x1

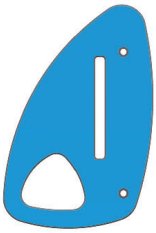

Mna018 x4



Mna019 x4

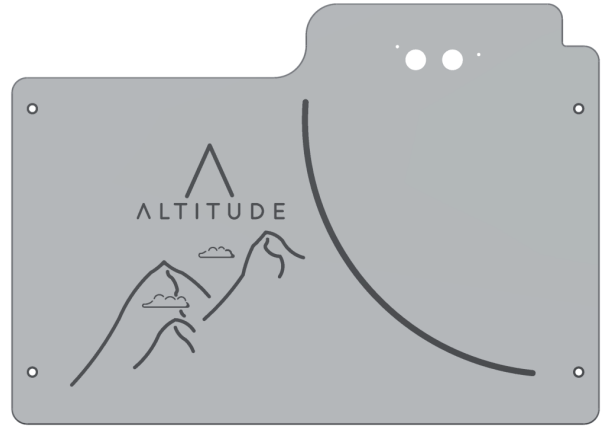

Mna026 x1

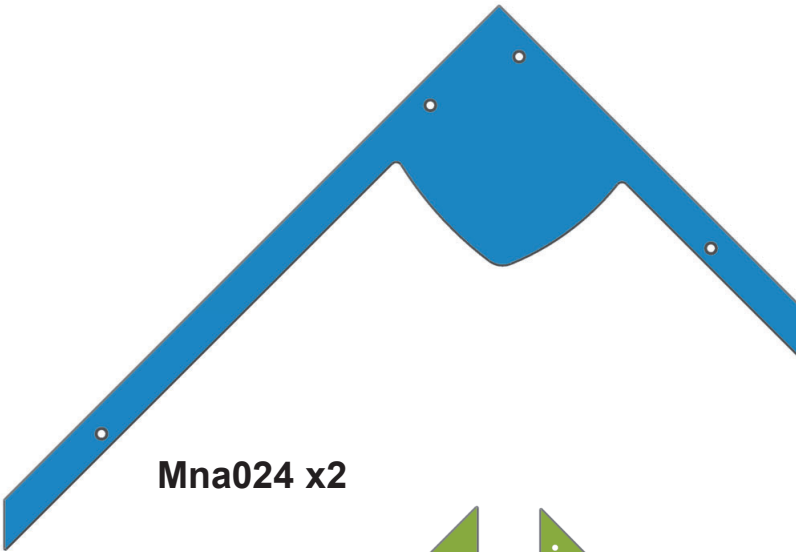

Mna024 x2

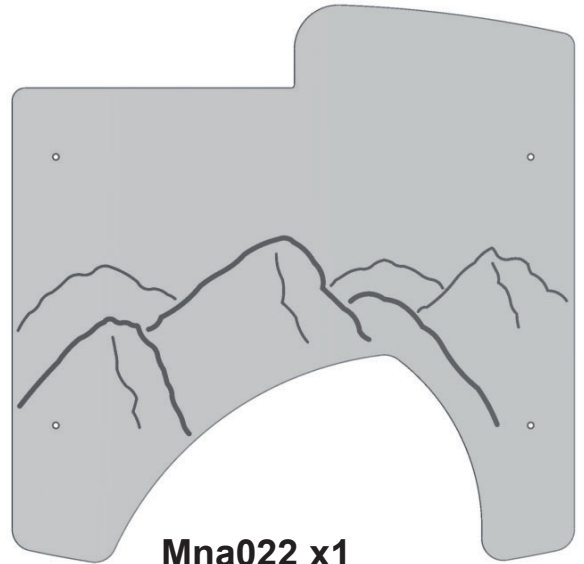

Mna022 x1

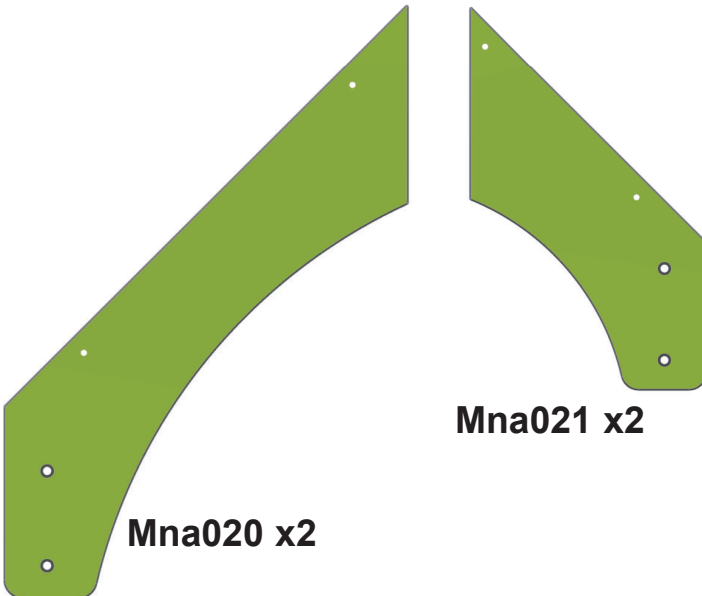

Mna020 x2

Mna021 x2

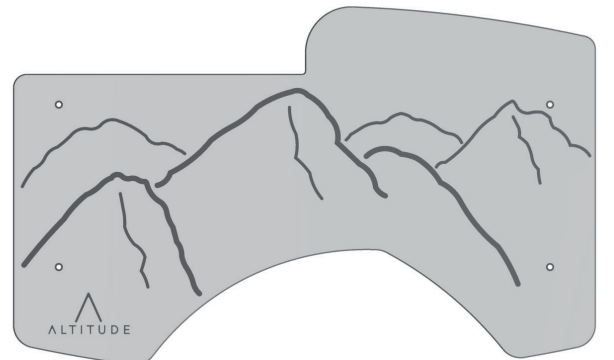

Mna023 x1

Mnw002

Standard Views



Mnw002

Standard Fixings

19mm THK Panel to Framework.

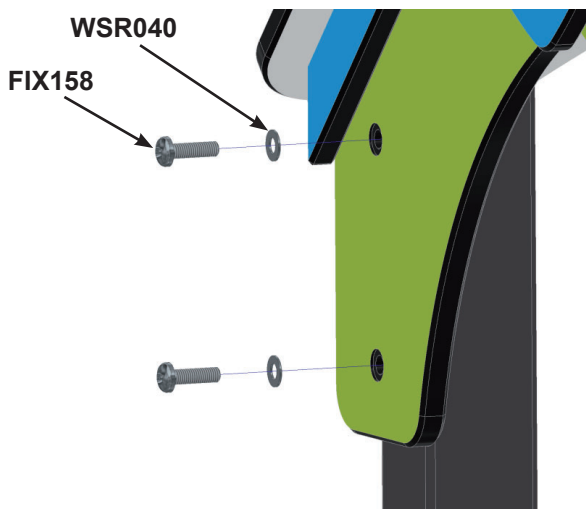

Ref	Description	Qty
WSR040	M10 Plain Washer	1
FIX158	M10 x 35 Security Bolt	1

5mm Plates to Framework.

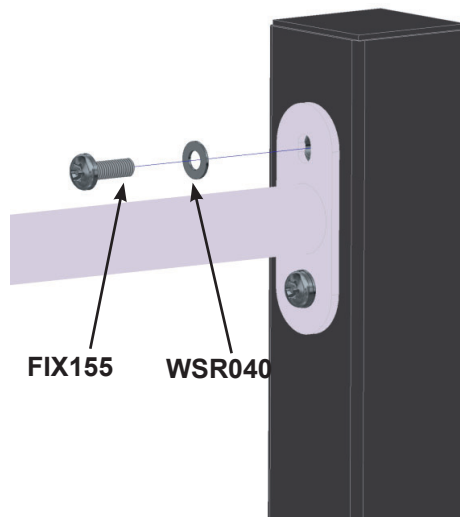

Ref	Description	Qty
WSR040	M10 Plain Washer	1
FIX155	M10 x 30 Security Bolt	1

Capping Holes.

FIX150
Cap all holes after unit is fully assembled.

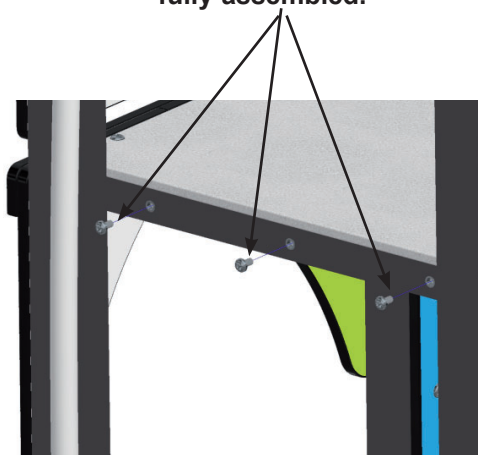

Ref	Description
FIX150	M10 x 20 Security Bolt

Mnw002

Deck Fixings

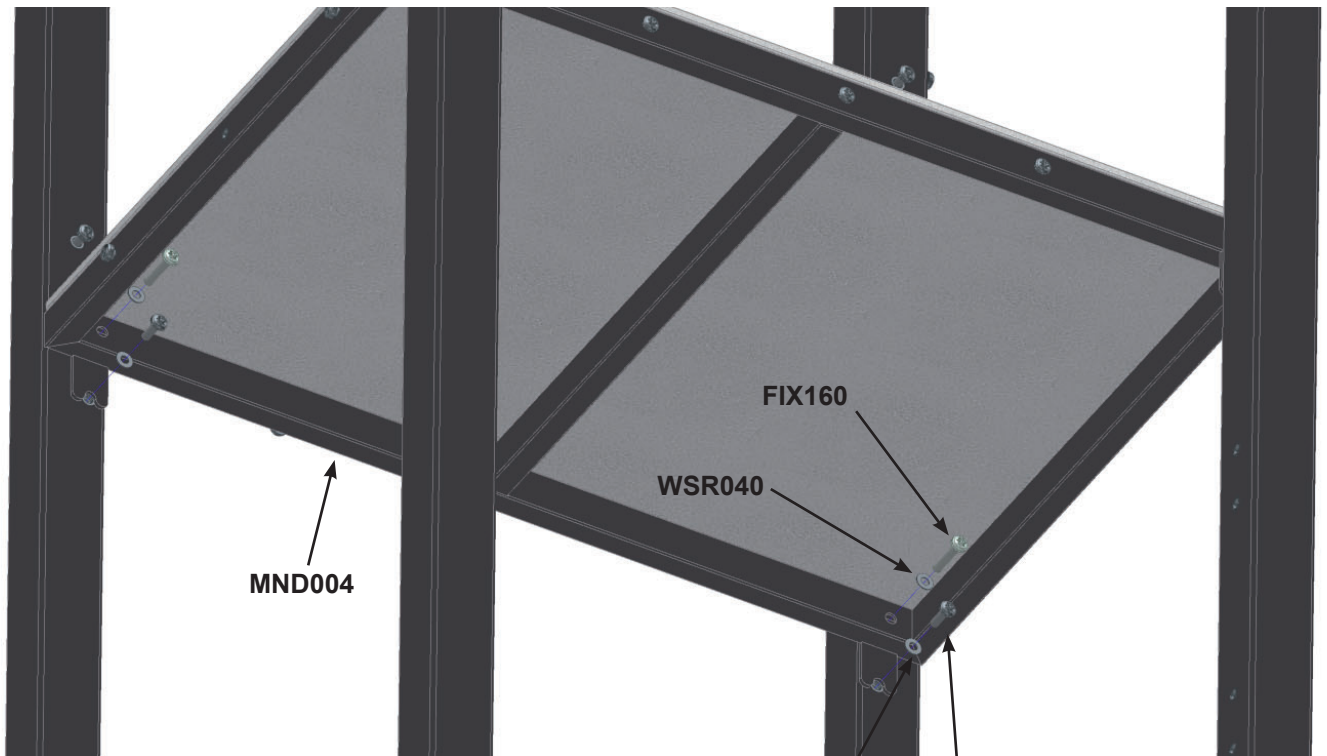

Ref	Description	Qty
MND004	Deck Assembly	1
WSR040	M10 Plain Washer	8
FIX155	M10 x 30 Security Bolt	4
FIX160	M10 x 50 Security Bolt	4

WSR040

FIX155

Mnw002

Unit Maintenance Instructions

NOTE

The warranty is invalidated if these instructions are not followed.
All wood needs annual inspection and retreatment where required.

Recommended Regular Inspection and Maintenance

	Interval Days				
	7	14	28	56	365
Check stability of structure, tighten connections if required.	<input type="checkbox"/>	<input type="checkbox"/>	<input type="checkbox"/>	<input checked="" type="checkbox"/>	<input type="checkbox"/>
Check all uprights at ground level for corrosion and/or rot. Replace any defective parts.	<input type="checkbox"/>	<input type="checkbox"/>	<input type="checkbox"/>	<input type="checkbox"/>	<input checked="" type="checkbox"/>
Check all painted elements for damage, rub down and repaint or replace as required.	<input type="checkbox"/>	<input type="checkbox"/>	<input type="checkbox"/>	<input checked="" type="checkbox"/>	<input type="checkbox"/>
Check chain/ropework assemblies for wear and damage, replace if required.	<input type="checkbox"/>	<input checked="" type="checkbox"/>	<input type="checkbox"/>	<input type="checkbox"/>	<input type="checkbox"/>
Check rotating and pivot points for wear and smooth running lubricate or replace if required.	<input type="checkbox"/>	<input type="checkbox"/>	<input checked="" type="checkbox"/>	<input type="checkbox"/>	<input type="checkbox"/>
Check rubber parts for wear and/or damage, replace if required.	<input type="checkbox"/>	<input type="checkbox"/>	<input checked="" type="checkbox"/>	<input type="checkbox"/>	<input type="checkbox"/>
Check tension cables, adjust if required.	<input type="checkbox"/>	<input type="checkbox"/>	<input checked="" type="checkbox"/>	<input type="checkbox"/>	<input type="checkbox"/>
Check wear of cables, replace if required.	<input type="checkbox"/>	<input type="checkbox"/>	<input checked="" type="checkbox"/>	<input type="checkbox"/>	<input type="checkbox"/>
Check slide chutes for smoothness and any foreign elements, remove any found.	<input type="checkbox"/>	<input type="checkbox"/>	<input checked="" type="checkbox"/>	<input type="checkbox"/>	<input type="checkbox"/>
Check rubber safety surfaces for damage and poor performance, repair or replace if required.	<input type="checkbox"/>	<input type="checkbox"/>	<input type="checkbox"/>	<input checked="" type="checkbox"/>	<input type="checkbox"/>
Check loose fill safety surfaces, remove any foreign elements, rake level and top up if required.	<input type="checkbox"/>	<input type="checkbox"/>	<input checked="" type="checkbox"/>	<input type="checkbox"/>	<input type="checkbox"/>

Disposal Instructions

All components should be broken down into categories of:-

- 1 **Mild Steel** - all activities and frames
- 2 **Stainless Steel** - all Slides, Mirror Panels.
- 3 **Aluminium** - all Playzone and Toddlerzone Posts.
- 4 **Galvanised Steel** - all Chains and Teenzone Posts.
- 5 **Moulded Rubber Products without steel inserts** - all Toddlerzone Caps and edge details.
- 6 **Timber** - all natural timber, plywood, and MDF panels.

Wherever possible these materials should be taken to specialist recycling organisations and recycled.

In some cases where composite materials are used, then disposal at land fill sites is the only alternative such as:

- 7 **Moulded Rubber Products encasing steel inserts** - all Swing Seats, Deck Tops, Duo/Dizzy Disc Tops.
- 8 **High Pressure Laminate** - all Toddlerzone, Playzone and Teenzone Panels.
- 9 **Steel Core Polypropylene Rope** - all Scramble Nets, Space Nets, Playzone/Toddlerzone Ropes.
- 10 **High Density Polyethylene** - Fantasy Range Panels.