

design
make
play

SutcliffePlay

Waggon Lane
Upton Pontefract
West Yorkshire WF9 1JS
Telephone +44 (0) 1977 653200
Facsimile +44 (0) 1977 653222
info@sutcliffeplay.co.uk
www.sutcliffeplay.co.uk



Altitude - Peak

Installation Instructions

Mnw010

Mnw010

Unit Installation Instructions

1. Check using the Parts List that none of the components are missing.
2. Plan the final position of the play equipment ensuring there is sufficient space.
3. Sort and identify parts before assembly.
4. Excavate the foundation holes in accordance with the plan. Ensuring post holes are levelled and chocked in at the bottom of the holes.
5. Position 2 x 300mm long spragging irons into the holes provided in each post upright and stand in the foundation holes.
Do not tighten the fixing bolts until all the activities have been assembled.
6. Assemble the activities onto the posts as per the diagrams in this document. Leave fixing bolts loose until all the activities have been assembled. Ground fixed activities need 200mm spragging irons positioned through their holes.
7. Assemble the slide as per the diagrams in this document.
8. When all activities have been assembled, tighten all the fixings, attach nut covers where necessary, ensure the unit is level and the posts are vertical.
9. Fill the foundation holes to the required depth with concrete.
10. Do not allow the equipment to be used until the concrete has set (2 - 3 days) and the required safety surfacing has been installed.
11. Tighten all fixing bolts.
12. Follow the maintenance instructions supplied.

NB:

1. Slide runouts should be inclined downwards by approximately 2 degrees for drainage purposes.
2. During installation care must be taken to prevent hazards to children.
3. Extra care should be taken if conditions are abnormal.

Mnw010

Unit
Parts List

design
make
play
SutcliffePlay

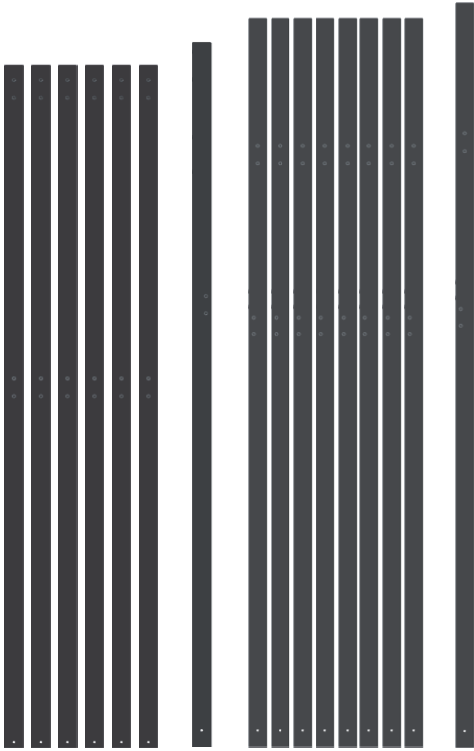

Mnp010 x1
Set of 16 Posts



Mna001 x3

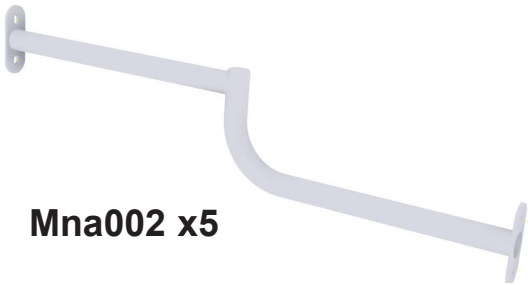

Mna002 x5



Mna028 x1



Mna009 x1

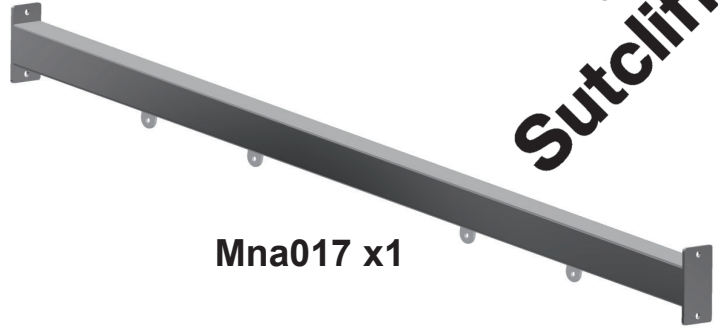

Mna017 x1

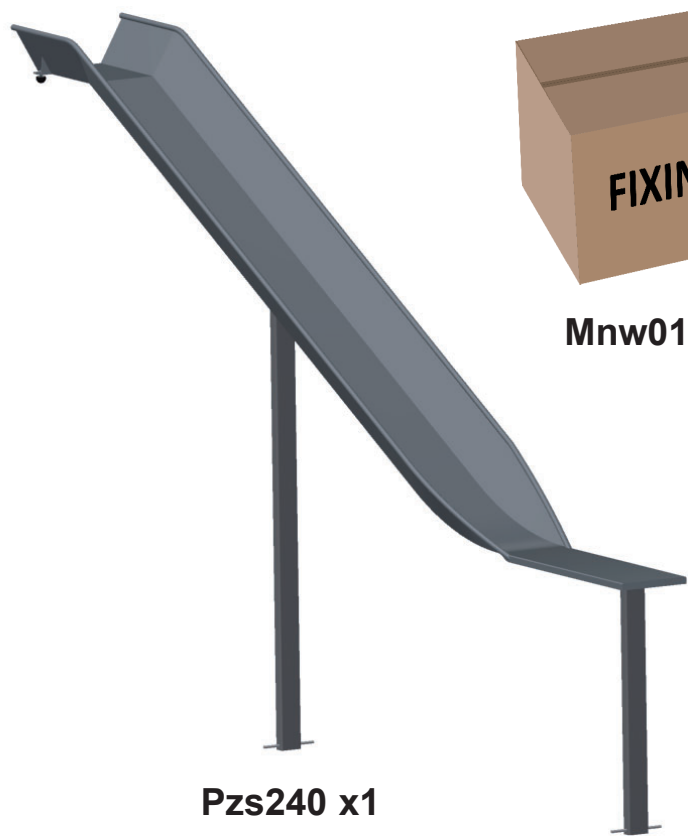

Pzs240 x1



Mnw010F x1



Mnd004 x3



Mnd006 x1

Mnw010

Unit
Parts List

design
make
play
SutcliffePlay

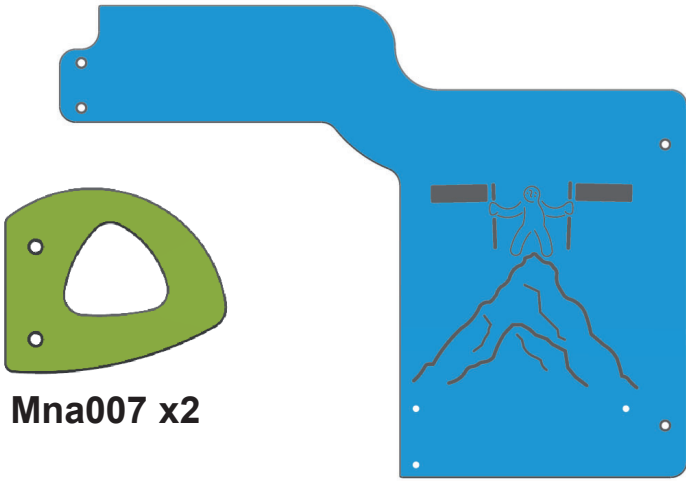

Mna007 x2

Mna005 x1

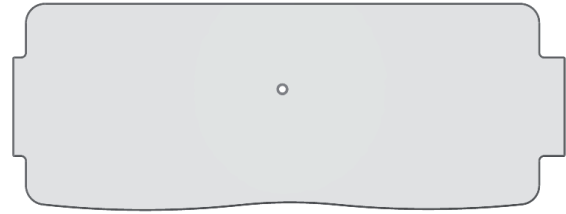

Mna010 x1



Mna011 x1



Mna008 x1



Mna006 x1



Mna012 x1

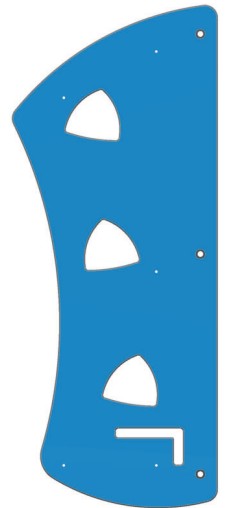

Mna013 x1

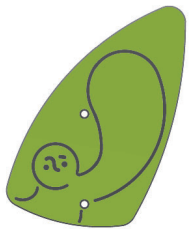

Mna014 x1

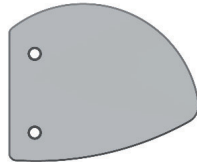

Mna015 x2

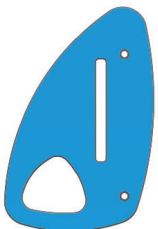

Mna018 x4



Mna019 x4

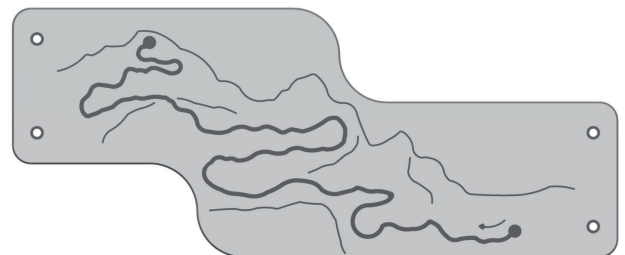

Mna031 x1

Mnw010

Unit
Parts List

design
make
play
SutcliffePlay

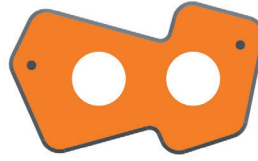

Mna027 x1

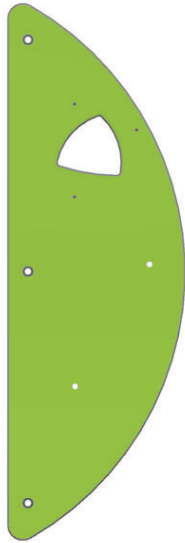

Mna034 x1

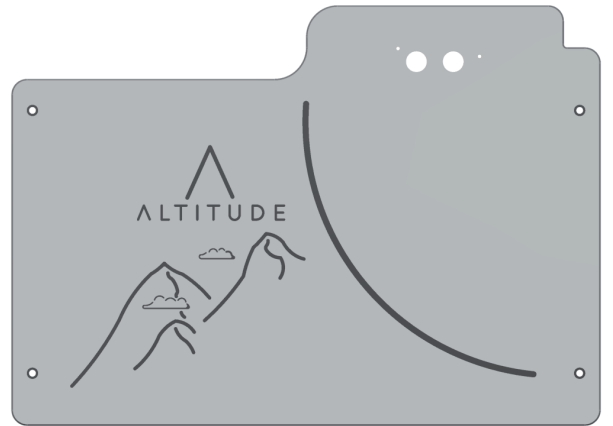

Mna026 x1

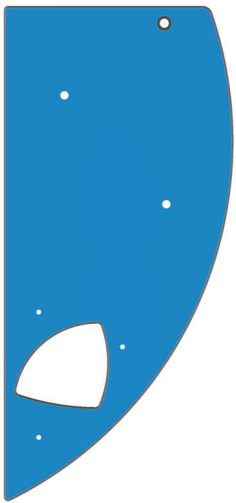

Mna035 x1

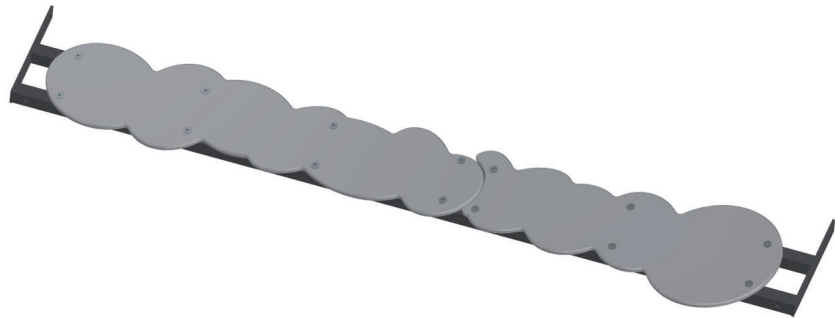

Mna040 x1

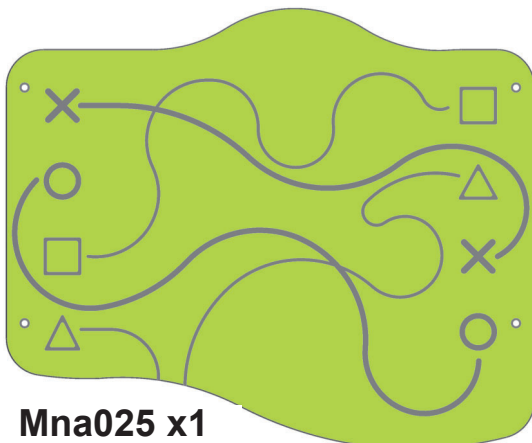

Mna025 x1

Mnw010

Unit
Parts List

design
make
play
SutcliffePlay

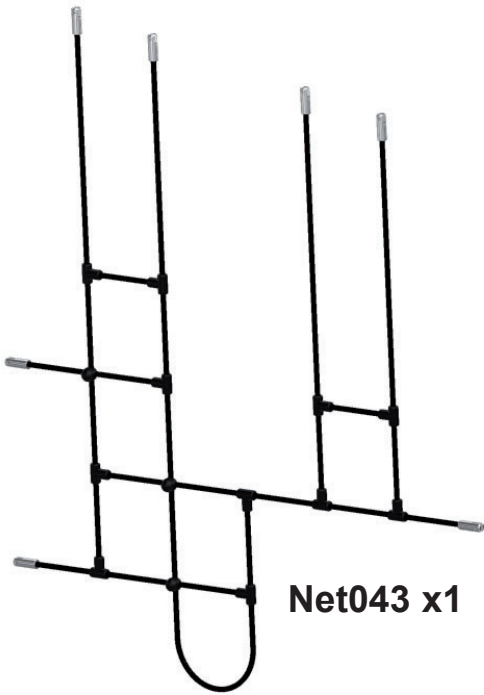

Net043 x1

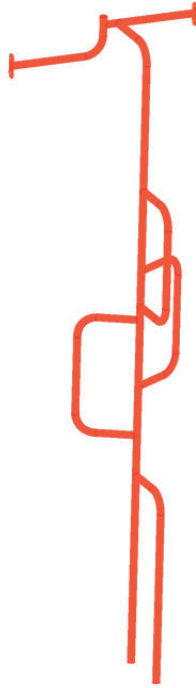

Mna029 x1

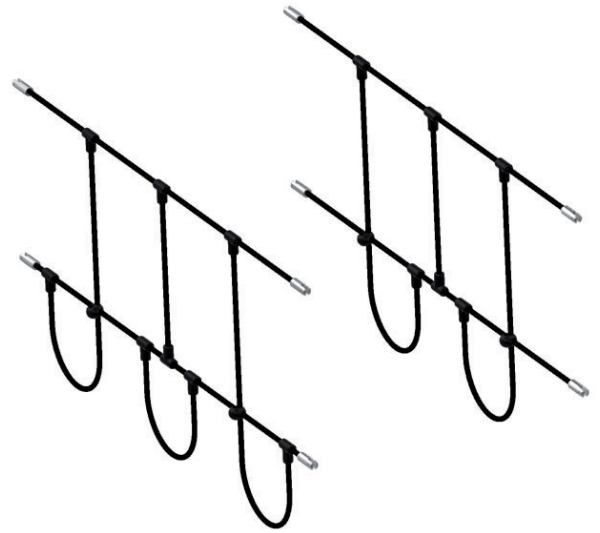

Net044 x1

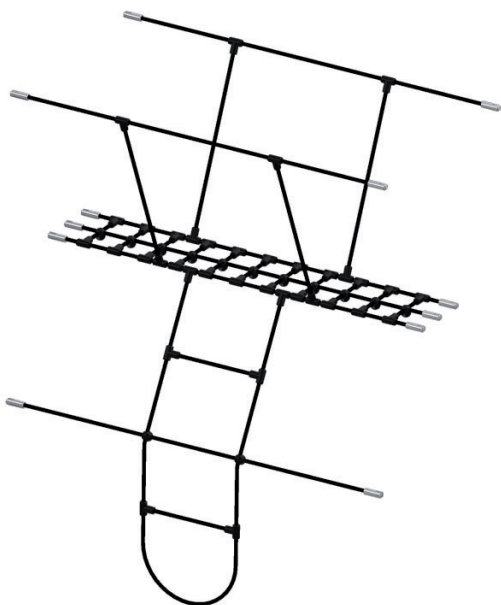

Net041 x1



Mna004 x1



Mna032 x1

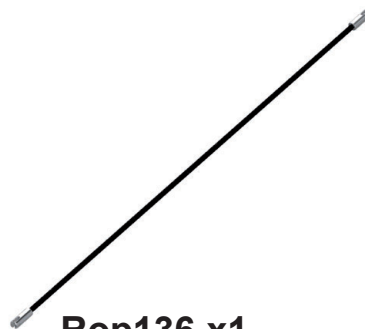

Rop136 x1

Mnw010

Standard Views

design
make
play
SutcliffePlay

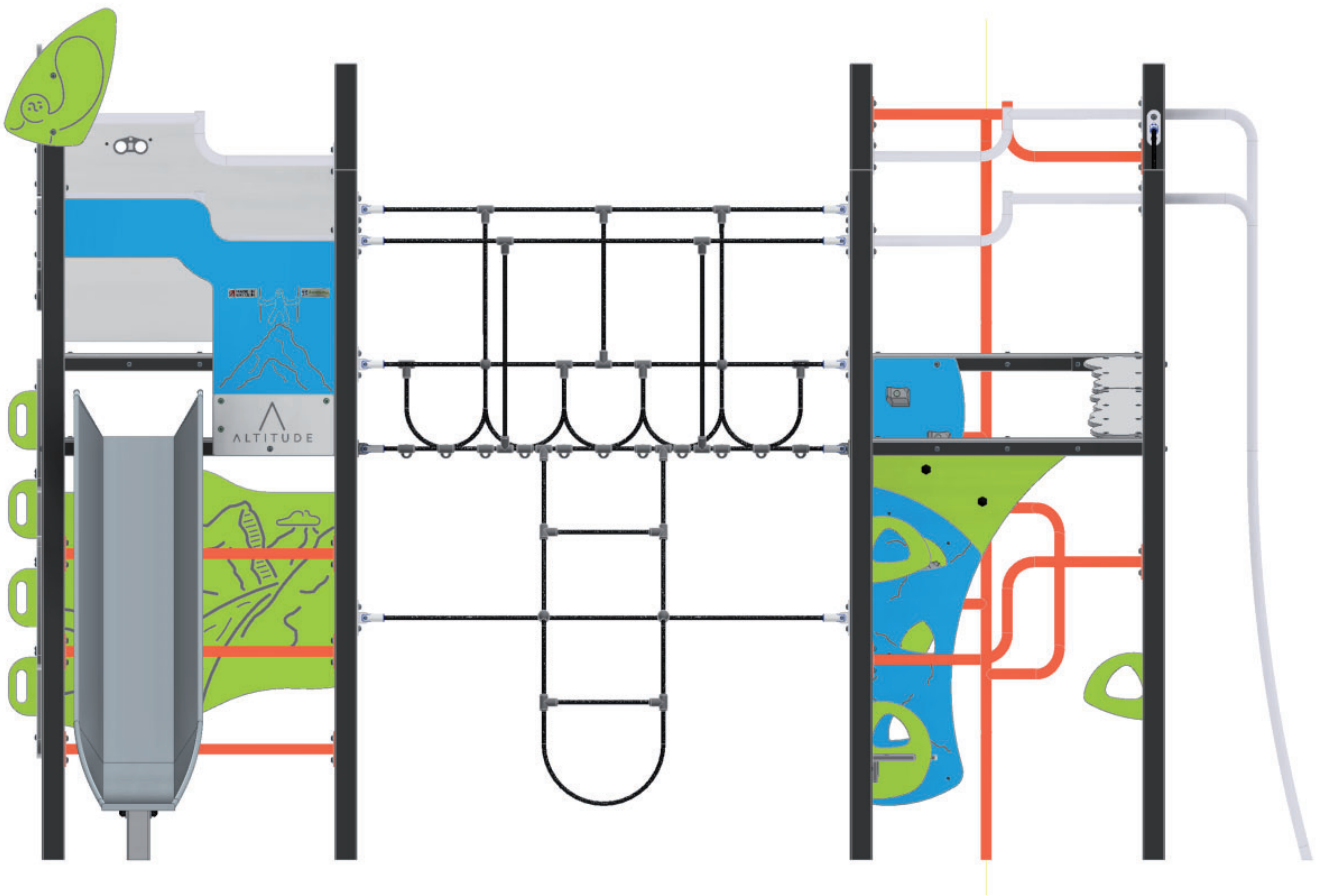
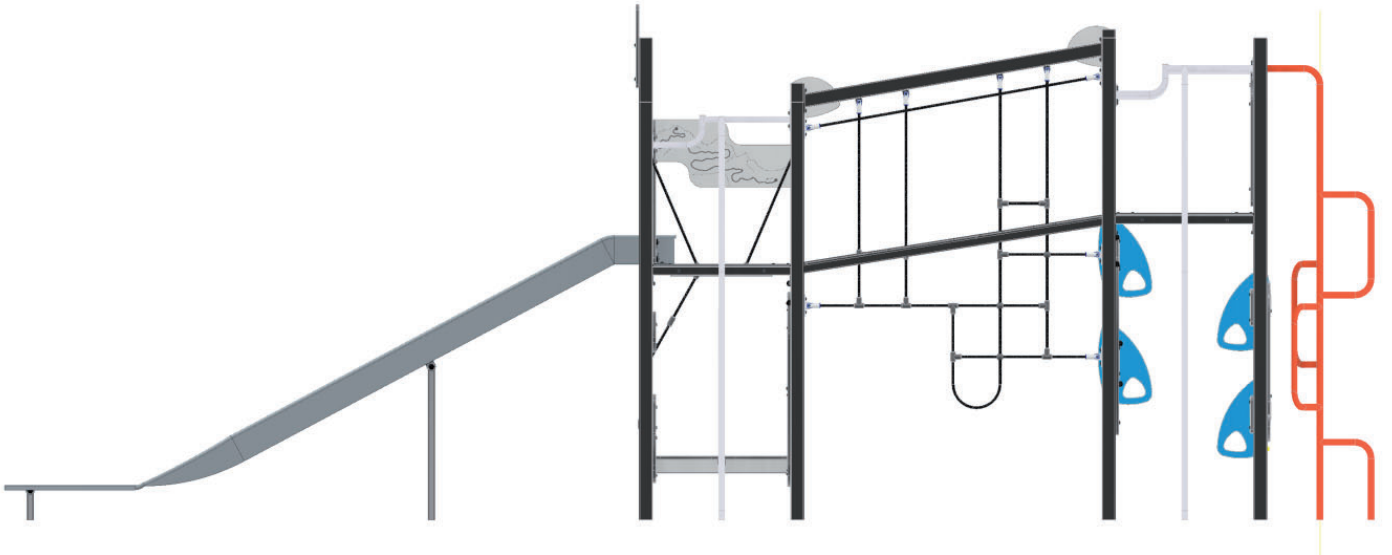

Mnw010

Standard Views

design
make
play
SutcliffePlay

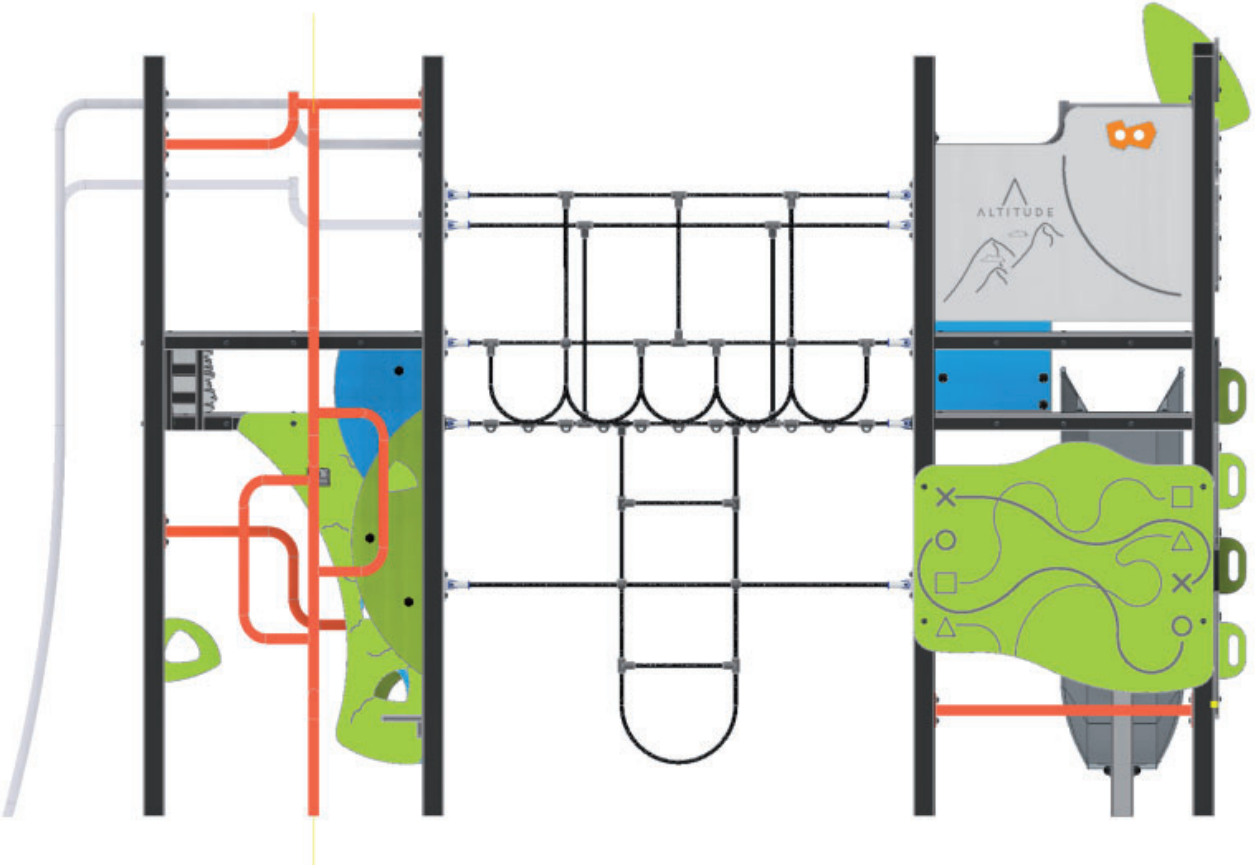

Mnw010

Standard Fixings

19mm THK Panel to Framework.

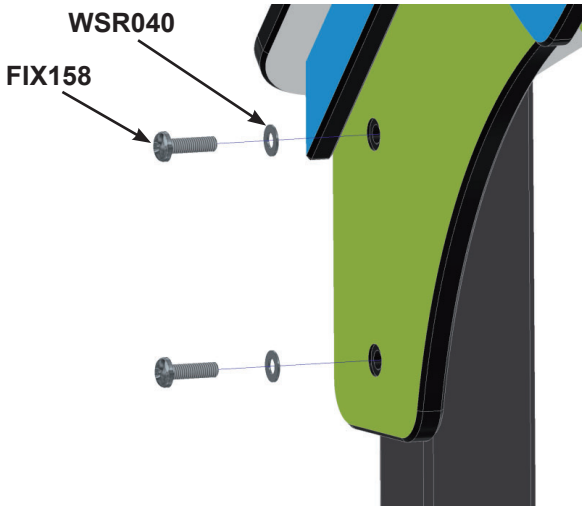

Ref	Description	Qty
WSR040	M10 Plain Washer	1
FIX158	M10 x 35 Security Bolt	1

5mm Plates to Framework.

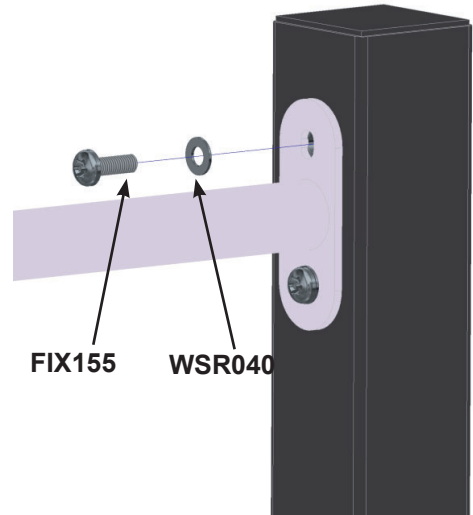

Ref	Description	Qty
WSR040	M10 Plain Washer	1
FIX155	M10 x 30 Security Bolt	1

19mm Panel to 19mm Panel.

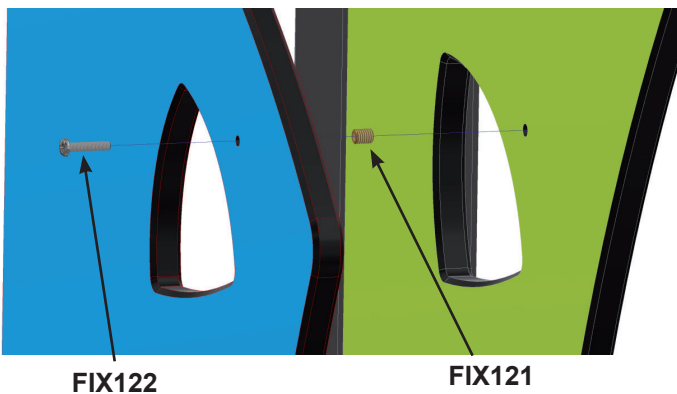

Ref	Description	Qty
FIX122	M5 x 25 Security bolt	1
FIX121	M5 Brass Insert	1

Capping Holes.

FIX150
Cap all holes after unit is fully assembled.

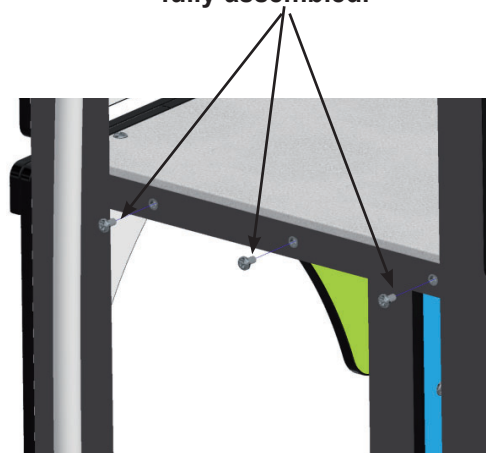

Ref	Description
FIX150	M10 x 20 Security Bolt

Mnw010

Deck Fixings

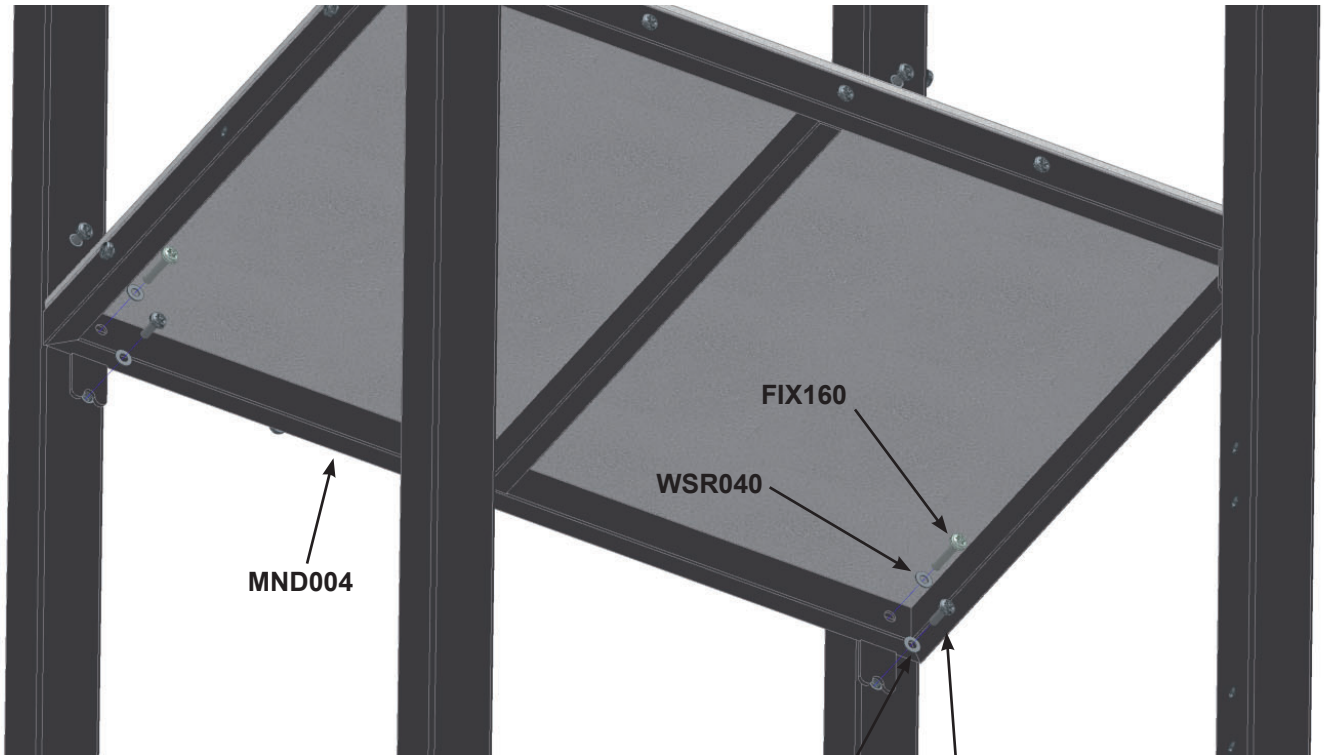

Ref	Description	Qty
MND004	Deck Assembly	1
WSR040	M10 Plain Washer	8
FIX155	M10 x 30 Security Bolt	4
FIX160	M10 x 50 Security Bolt	4

WSR040

FIX155

Mnw010

Slide Assembly

1.

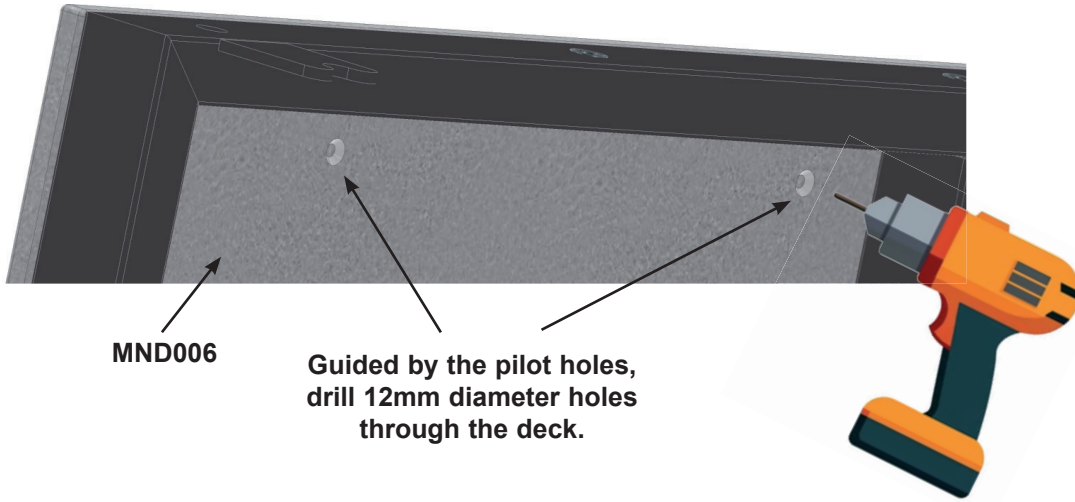

2.

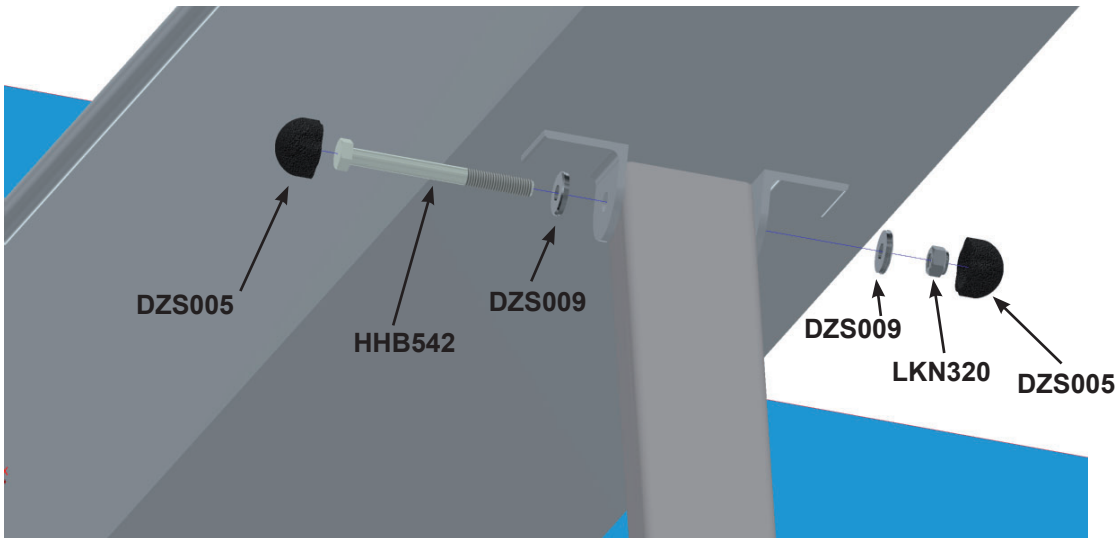

Mnw010

Slide Assembly

3.

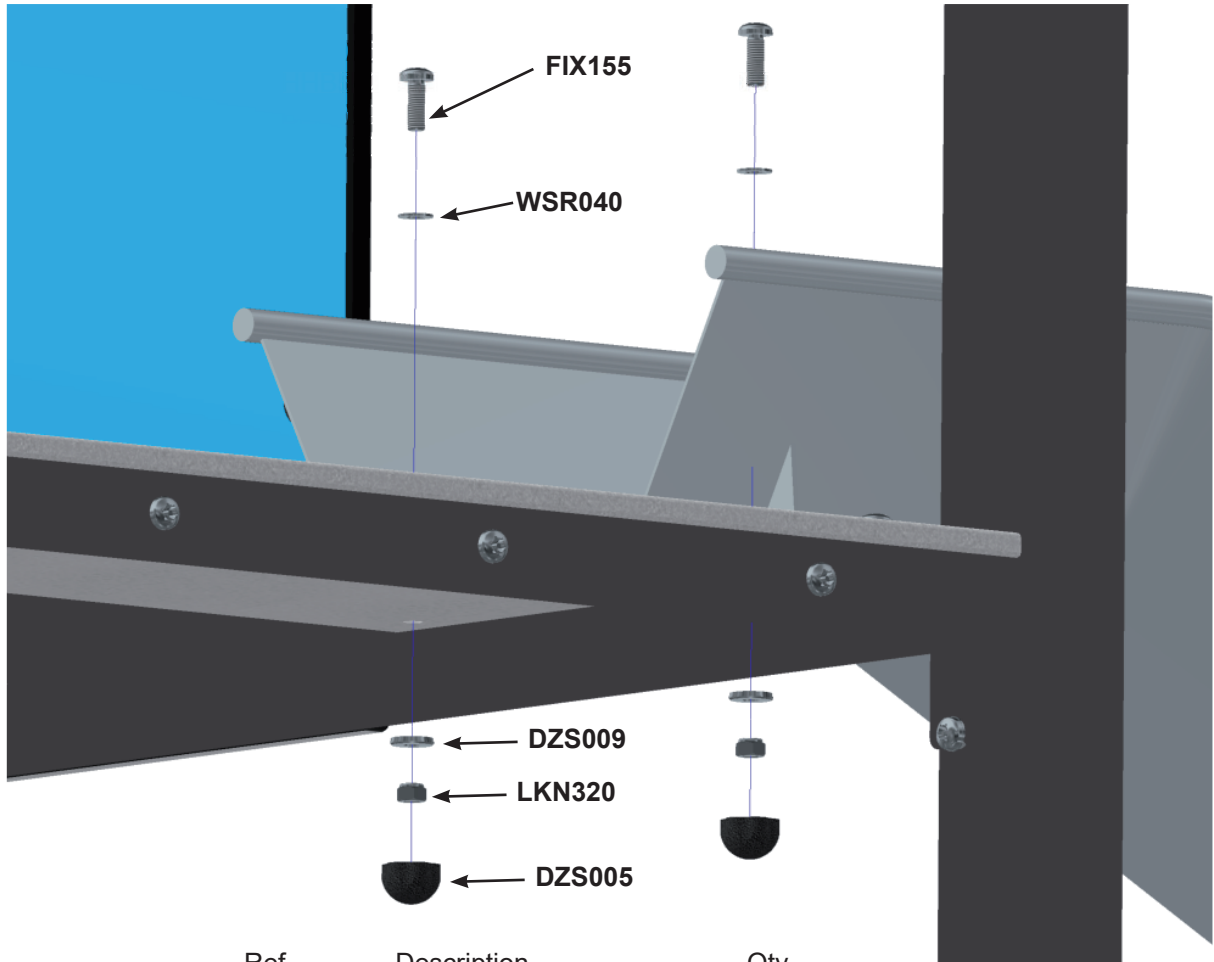

Ref	Description	Qty
DZS005	M10 NUT COVER	2
DZS009	M10 COVER WASHER	2
LKN320	M10 NYLOC NUT	2
FIX155	M10 x 30 SECURITY SCREW	2
WSR040	M10 PLAIN WASHER	2

Mnw010

Assembly Fixings

Seat Assembly.

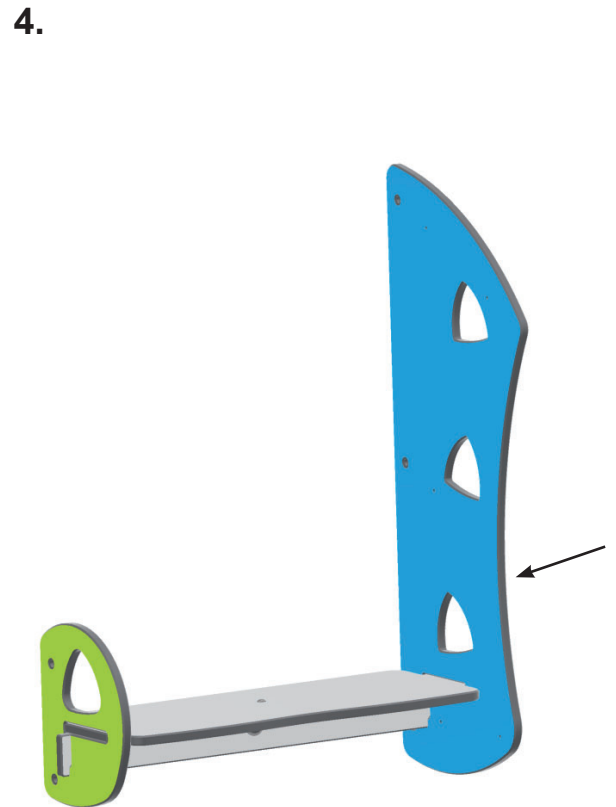
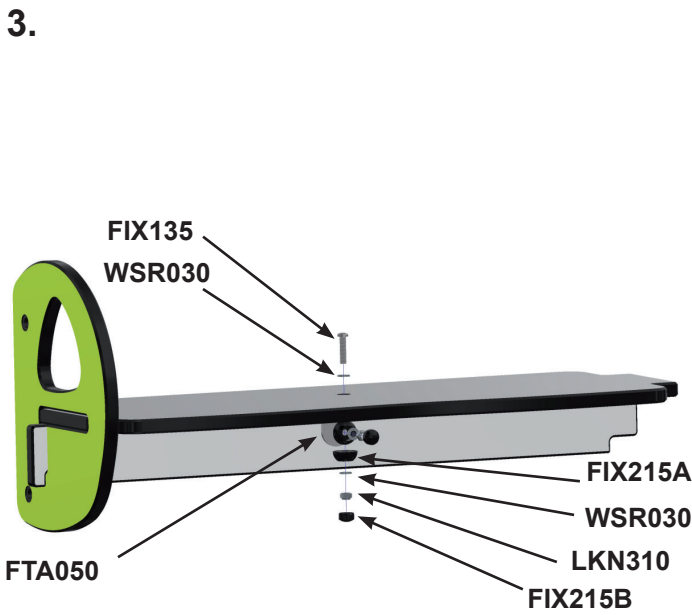
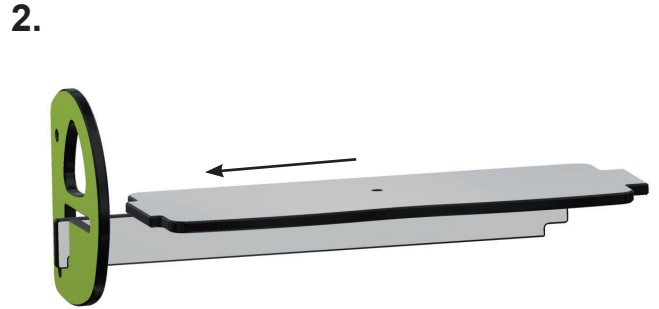
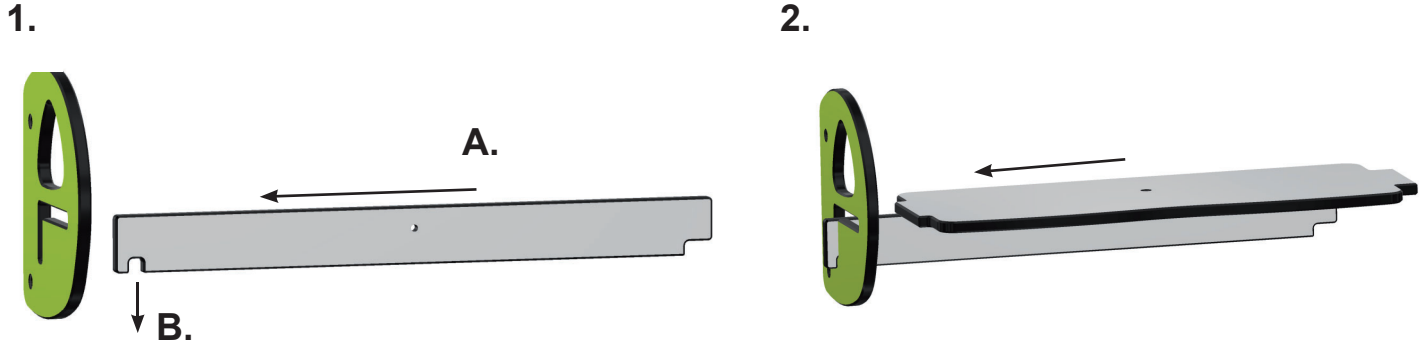

Ref	Description	Qty
WSR030	M8 Plain Washer	4
FIX135	M8 x 35 Security Bolt	2
FIX215A	M8 2 Part Cover - Base	2
LKN310	M8 Nyloc Nut	2
FIX215B	M8 2 Part Cover - Cap	2
FTA050	L-Bracket 50 x 50 St/St	1

Mnw010

Assembly Fixings

Seat Assembly.

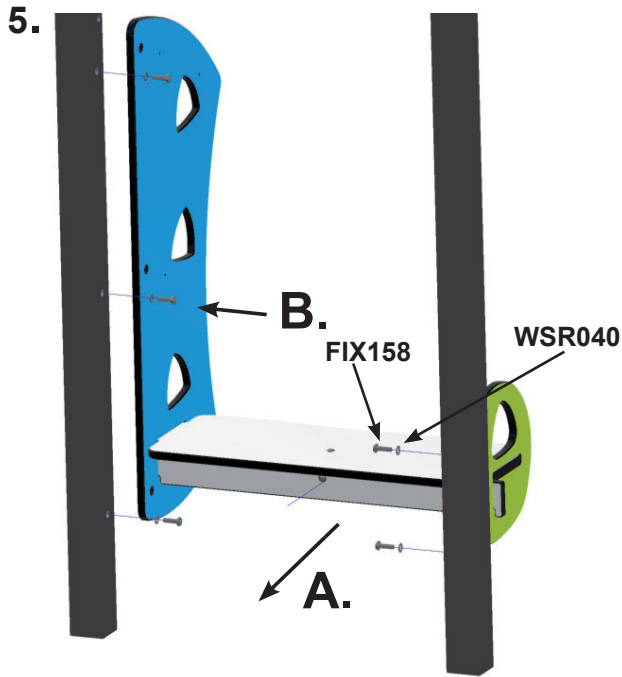

Ref	Description	Qty
WSR040	M10 Plain Washer	5
FIX158	M10 X 35 Security Bolt	5

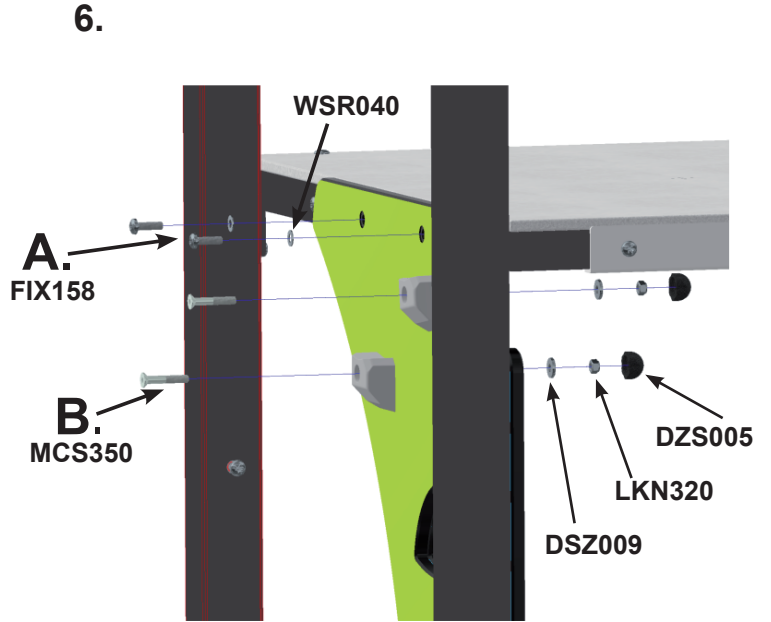

Ref	Description	Qty
WSR040	M10 Plain Washer	2
FIX158	M10 X 35 Security Bolt	2
MCS350	M10 x 60 Hex C/sink Screw	2
DSZ009	M10 Cover Washer	2
LKN320	M10 Nyloc Nut	2
DSZ005	M10 Nut Cover	2

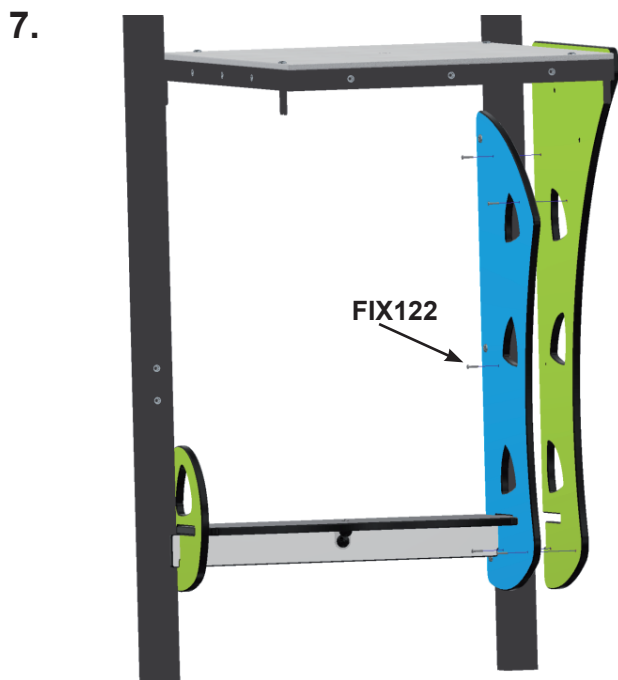

Ref	Description	Qty
FIX122	M5 x 25 Security Bolt	5

Mnw010

Assembly Fixings

V-Bridge Assembly.

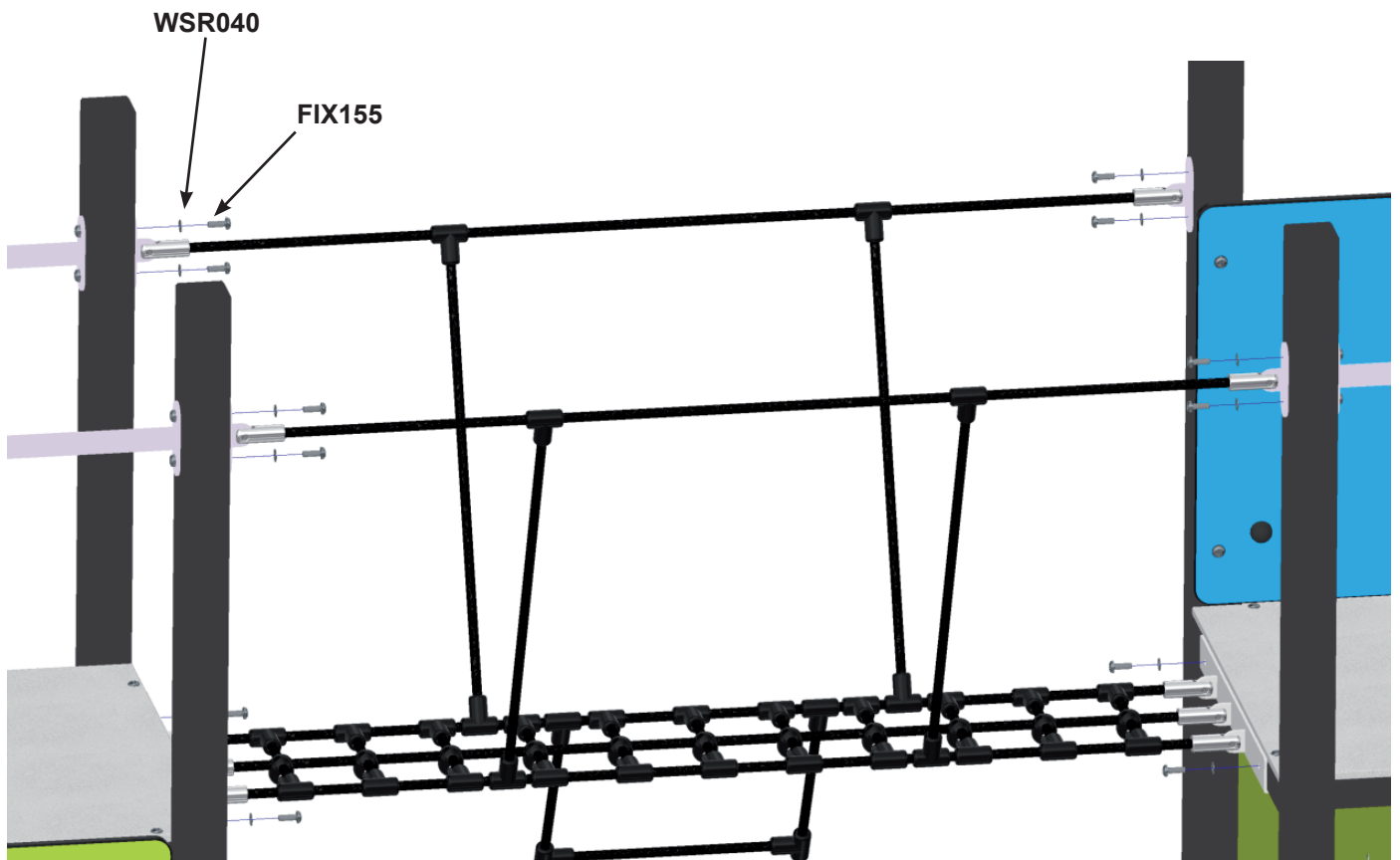

Ref	Description	Qty
WSR040	M10 Plain Washer	12
FIX155	M10 x 30 Security Bolt	12

Mnw010

Assembly Fixings

Step Net + Cross Beam Assembly.

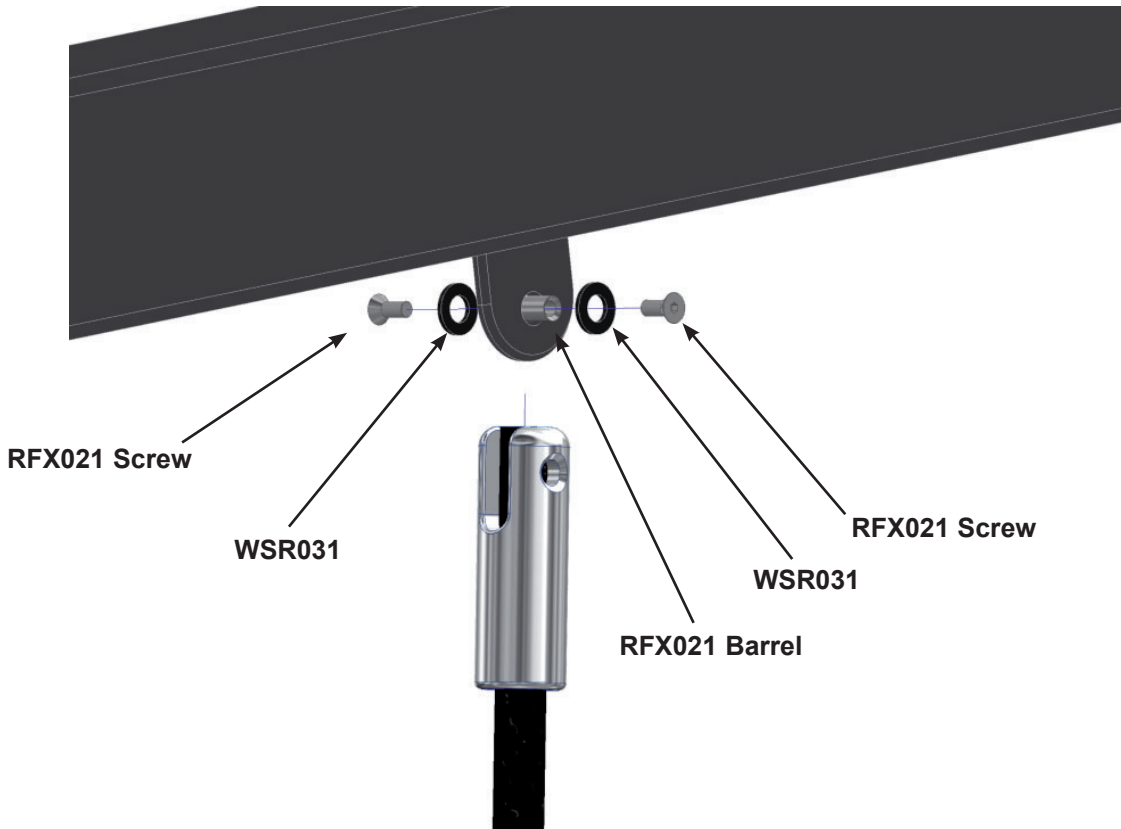

Mnw010

Assembly Fixings

Stepping Stones Bridge Assembly.

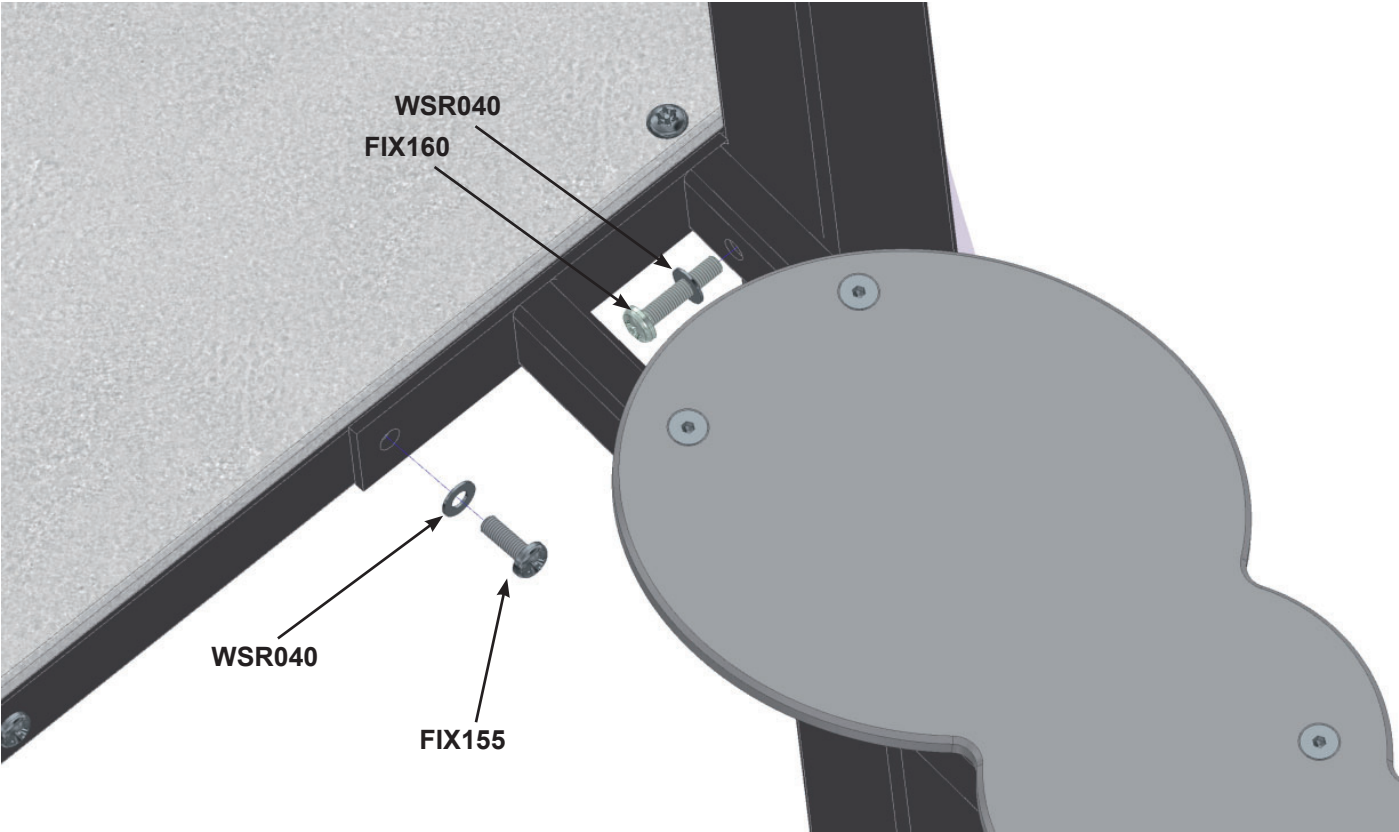

Mnw010

Unit Maintenance Instructions



NOTE

The warranty is invalidated if these instructions are not followed.
All wood needs annual inspection and retreatment where required.

Recommended Regular Inspection and Maintenance

	Interval Days				
	7	14	28	56	365
Check stability of structure, tighten connections if required.	<input type="checkbox"/>	<input type="checkbox"/>	<input type="checkbox"/>	<input checked="" type="checkbox"/>	<input type="checkbox"/>
Check all uprights at ground level for corrosion and/or rot. Replace any defective parts.	<input type="checkbox"/>	<input type="checkbox"/>	<input type="checkbox"/>	<input type="checkbox"/>	<input checked="" type="checkbox"/>
Check all painted elements for damage, rub down and repaint or replace as required.	<input type="checkbox"/>	<input type="checkbox"/>	<input type="checkbox"/>	<input checked="" type="checkbox"/>	<input type="checkbox"/>
Check chain/ropework assemblies for wear and damage, replace if required.	<input type="checkbox"/>	<input checked="" type="checkbox"/>	<input type="checkbox"/>	<input type="checkbox"/>	<input type="checkbox"/>
Check rotating and pivot points for wear and smooth running lubricate or replace if required.	<input type="checkbox"/>	<input type="checkbox"/>	<input checked="" type="checkbox"/>	<input type="checkbox"/>	<input type="checkbox"/>
Check rubber parts for wear and/or damage, replace if required.	<input type="checkbox"/>	<input type="checkbox"/>	<input checked="" type="checkbox"/>	<input type="checkbox"/>	<input type="checkbox"/>
Check tension cables, adjust if required.	<input type="checkbox"/>	<input type="checkbox"/>	<input checked="" type="checkbox"/>	<input type="checkbox"/>	<input type="checkbox"/>
Check wear of cables, replace if required.	<input type="checkbox"/>	<input type="checkbox"/>	<input checked="" type="checkbox"/>	<input type="checkbox"/>	<input type="checkbox"/>
Check slide chutes for smoothness and any foreign elements, remove any found.	<input type="checkbox"/>	<input type="checkbox"/>	<input checked="" type="checkbox"/>	<input type="checkbox"/>	<input type="checkbox"/>
Check rubber safety surfaces for damage and poor performance, repair or replace if required.	<input type="checkbox"/>	<input type="checkbox"/>	<input type="checkbox"/>	<input checked="" type="checkbox"/>	<input type="checkbox"/>
Check loose fill safety surfaces, remove any foreign elements, rake level and top up if required.	<input type="checkbox"/>	<input type="checkbox"/>	<input checked="" type="checkbox"/>	<input type="checkbox"/>	<input type="checkbox"/>

Disposal Instructions

All components should be broken down into categories of:-

- 1 **Mild Steel** - all activities and frames
- 2 **Stainless Steel** - all Slides, Mirror Panels.
- 3 **Aluminium** - all Playzone and Toddlerzone Posts.
- 4 **Galvanised Steel** - all Chains and Teenzone Posts.
- 5 **Moulded Rubber Products without steel inserts** - all Toddlerzone Caps and edge details.
- 6 **Timber** - all natural timber, plywood, and MDF panels.

Wherever possible these materials should be taken to specialist recycling organisations and recycled.

In some cases where composite materials are used, then disposal at land fill sites is the only alternative such as:

- 7 **Moulded Rubber Products encasing steel inserts** - all Swing Seats, Deck Tops, Duo/Dizzy Disc Tops.
- 8 **High Pressure Laminate** - all Toddlerzone, Playzone and Teenzone Panels.
- 9 **Steel Core Polypropylene Rope** - all Scramble Nets, Space Nets, Playzone/Toddlerzone Ropes.
- 10 **High Density Polyethylene** - Fantasy Range Panels.